



ECA Clutch Installation Guide

STOP!

READ CAREFULLY BEFORE INSTALLING CLUTCH

This clutch must be installed by a qualified installer. Improper installation or failure to replace or resurface the flywheel to the OE engine manufacturer's recommended dimensions, or to replace the pilot bearing, low-capacity inertia brake (LCIB) or other worn drive train components may cause poor clutch release or early failure and void the manufacturer's warranty.

Verify Correct Flywheel Dimensions

Flywheel bore (DIM A) must be a minimum of 10". (See Fig. 1)

Fig. 1

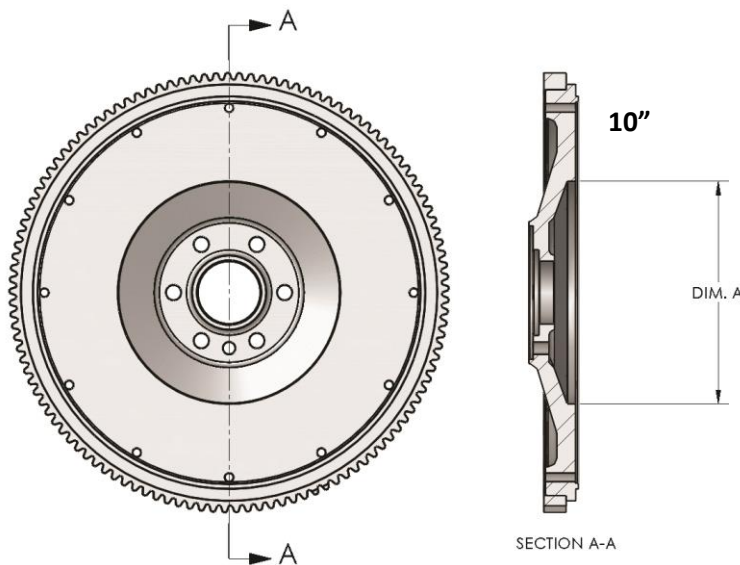
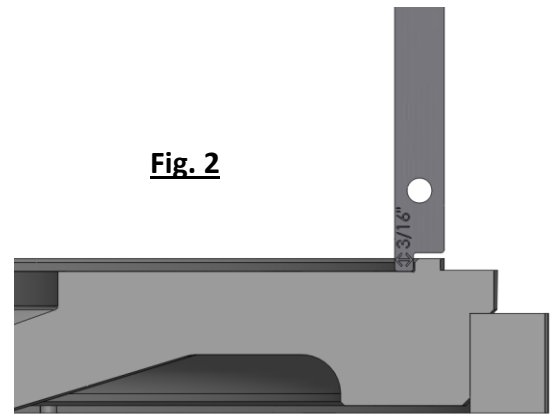

Fig. 2



Flywheel clutch pilot cannot be greater than 3/16" deep. If it is greater than 3/16" the clutch will not bolt tight to flywheel. (See Fig. 2)

Please reference OEM specifications on flywheel thickness if you are resurfacing the flywheel.

MEASURING ENGINE FLYWHEEL HOUSING AND FLYWHEEL

NOTE: Pilot Bearing must be replaced. Make sure all gauge contact surfaces are clean and dry.

CHECK THE FOLLOWING USING A DIAL INDICATOR:

Fig. 3

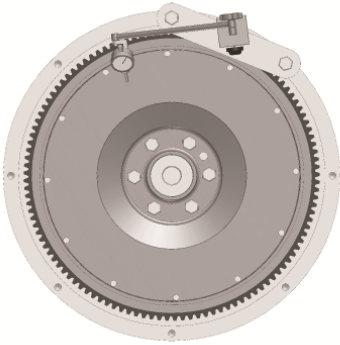

Flywheel Face Runout

Secure dial indicator base to flywheel housing face. Put gauge finger in contact with flywheel face near the outer edge. Rotate flywheel one revolution. Maximum runout is .008" (.20 mm).

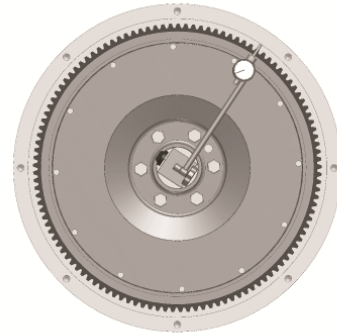

Flywheel Housing I.D. Runout

Secure dial indicator base to crankshaft. Put gauge finger against flywheel housing pilot I.D. Rotate flywheel one revolution. Maximum runout is .008 (.20 mm).

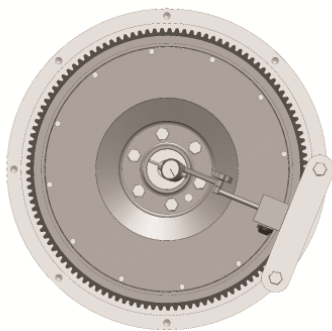

Pilot Bearing Bore Runout

Secure dial indicator base to flywheel housing face. Position gauge finger so that it contacts pilot bearing bore. Rotate flywheel one revolution. Maximum runout is .005" (.13 mm).

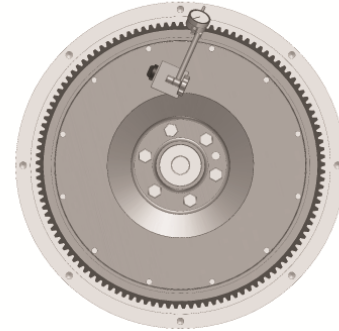

Flywheel Housing Face Runout

Secure dial indicator base to flywheel near the outer edge. Put gauge finger in contact with face of flywheel housing. Rotate flywheel one revolution. Maximum runout is .008" (.20 mm).

INSTALLATION

1. Inspect and dial-indicate the mating surface of engine flywheel housing and clutch bell housing for alignment. Check flywheel runout. **CAUTION:** If misalignment is greater than the recommended limits, this will cause poor clutch release, rapid wear on transmission input shaft and destruction of the clutch disc. Excessive flywheel runout may cause severe vibration in vehicle drive line (See Fig. 3).
2. A new pilot bearing with a VITON® seal must be used. Before installing pilot bearing into flywheel, check freedom of movement on transmission input shaft.
3. Verify disc fits in flywheel bore (Fig. 1). Slide disc the length of the input shaft checking for twist and wear. Insert alignment shaft through bearing housing. Install rear disc (oriented correctly), center plate, and front disc (oriented correctly) on alignment shaft. Move clutch housing towards flywheel making sure cover fits into flywheel pilot.
4. Install the bolts (7/16 x 14unc x 2-1/4) that fasten the clutch housing on the flywheel. Tighten the bolts to the specified torque and the sequence specified by the manufacturer of the vehicle or transmission (Recommended 40-50 ft*lbs). Bolts should be Grade 5 or greater.
5. Remove caging fork from under the release bearing. Remove alignment shaft. **NOTE: Any time the clutch is removed from the flywheel, the caging fork needs to be reinstalled. Failure to do so will cause adjusting arm to fall out of retainer stud. See Fig. 8 in Reset Procedure.**
6. Examine transmission input shaft and clutch release system components for wear and if necessary, replace (See Fig. 4 on next page).
7. Replace the low-capacity inertia brake (ICIB) and torque fasteners to OE specifications.
8. Using extreme caution, guide transmission through clutch cover, disc assemblies, and into pilot bearing rotating bell housing shaft so that ECA release yoke fingers are clear of the pads on the release bearing assembly. (**Warning:** Transmission must not hang or be forced into the clutch. This can warp the clutch disc and prevent the clutch from releasing.) **NOTE: Do not add lube to input shaft splines!**
9. Start bell housing bolts and tighten progressively to the torque recommended by the vehicle manufacturer.
10. Reconnect lube hose attachment through inspection hole in bell housing.
Note: Be sure to properly lube the following components with NLGI grade 2 or 3 lithium complex grease: Release Bearing, Yoke Fingers, and Cross Shaft Bushings. Note: Applying enough grease to the release bearing until visible will extend the life of sleeve bushings and input shaft.
11. Install ECA if it was removed and run clutch adjustment program with correct software program.

Fig. 4

Cross Shaft

Worn cross shafts can lead to adjustment problems, as well as, premature sleeve bushing wear

Release Yoke

Worn fingers will cause sleeve bushing wear and adjustment problems

Transmission Bearing

Wear will allow input shaft wobble creating vibration which leads to premature failure

Cross Shaft Bushings

Worn bushings allows sideways thrust on release bearing causing wear on sleeve bushing and premature wear on release bearing

Input Shaft

Roughness in bushing area will lead to sleeve bushing failure and can cause bushing to pull out of sleeve

Input Shaft Splines

Worn splines on input shaft will cause clutch to release improperly and may cause splined hubs in clutch disc to break out

Input Shaft Pilot

Any wear in area will allow input shaft to wobble creating vibration which leads to premature failure

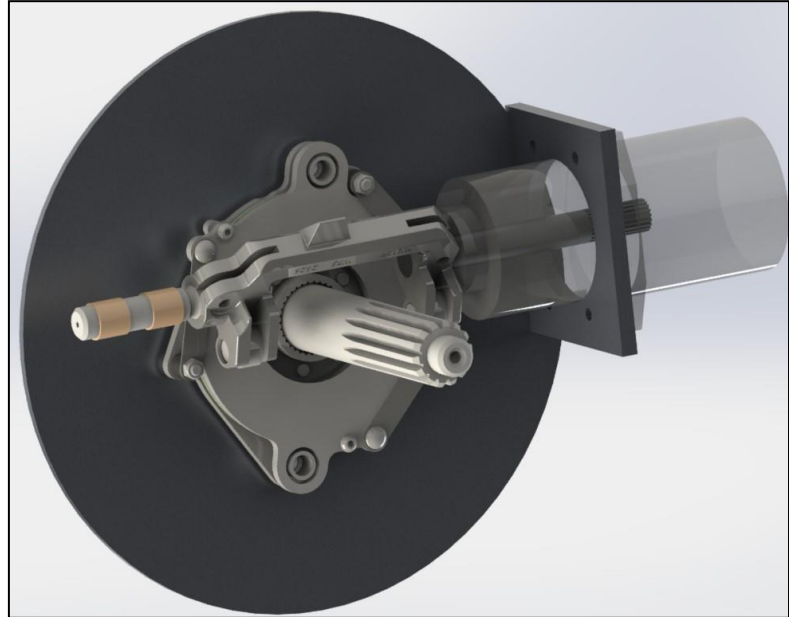

CLUTCH SETUP PROCEDURE

NOTE: Clutches are adjusted at the factory to original equipment (new flywheel) specifications and should require very little internal adjustment to achieve proper release and engagement. The clutch may need to be adjusted slightly to accommodate new or resurfaced flywheels. If adjustment is necessary, refer to OE diagnostics software to disengage clutch to allow for adjustment.

In addition, clutch must not be adjusted for worn linkage, yoke and/or cross shaft bushings, or to accommodate other drive train deficiencies. Adjustment for such purposes will either cause the clutch to not function properly or will cause early clutch failure and will be apparent on factory inspection of warranty claims, thereby voiding the manufacturer warranty.

Check for proper low-capacity inertia brake (LCIB) and bearing gap of $\frac{1}{2}$ ".

THIS DIMENSION IS CRITICAL. DO NOT VARY—EITHER OVER OR UNDER THESE DIMENSIONS—UNDER ANY CIRCUMSTANCES.

REMINDER: The bearing must move a minimum of $\frac{1}{2}$ " or clutch will not release. Eliminate lost motion before checking for $\frac{1}{2}$ " movement. Lost motion is generally caused by loose or worn yoke or cross shaft bushings.

Fig. 5

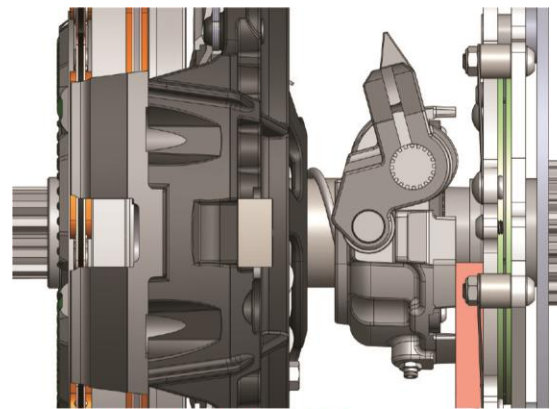

Use set-up tool provided

$\frac{1}{2}$ "

Is this dimension correct?

The $\frac{1}{2}$ " measurement MUST be taken with the inertia brake (LCIB) compressed.

RESET PROCEDURE

If for any reason the clutch needs to be reset or manually adjusted, follow the instructions below.

1. Remove self-adjusting mechanism (Fig. 6)
2. Refer to OE diagnostics software to disengage clutch to allow for adjustment.
3. Install manual adjust mechanism (Fig. 6)
4. Manually adjust clutch to meet specs in set up procedure. (Fig. 5)
5. Reinstall self-adjusting mechanism. Ensure adjusting arm is properly seated in the retainer stud (Fig. 7).
6. When reinstalling self-adjusting mechanism, it may be necessary to manually ratchet the self-adjust mechanism so that the worm gear is seated properly in the adjusting ring teeth.

Fig. 6

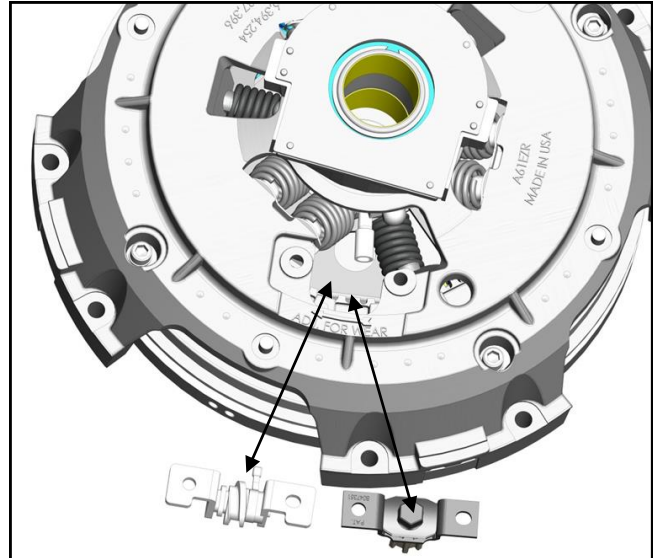
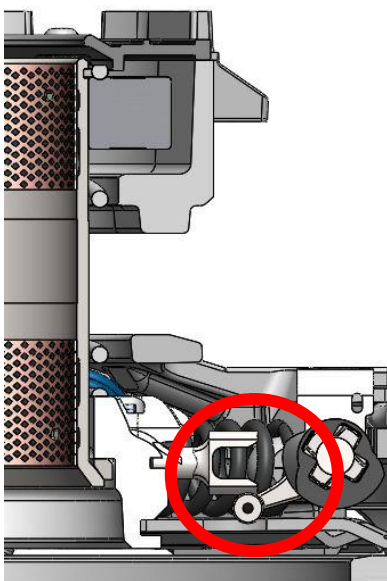
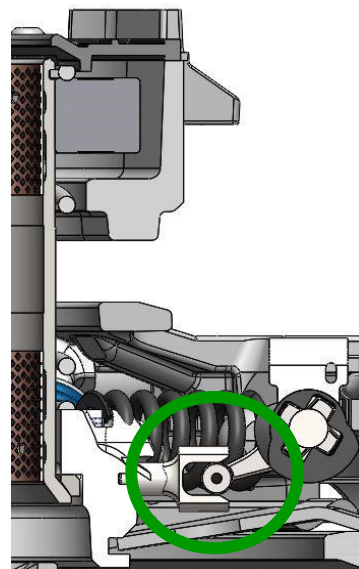

Fig. 7

Incorrect



Correct





Limited Warranty

This heavy-duty clutch is warranted against defective material or workmanship for a period of three (3) years, unlimited mileage, conditions apply. Conditions: Failure to replace pilot bearing, worn release system components or properly resurface flywheel at the time of installation voids the clutch warranty. Friction material is covered only for manufacturing/material defects and excludes issues that arise from normal wear. Products rendered defective by improper installation, misapplication, contamination, abuse, alteration, or any improper adjustment are not warrantable. It is the user's responsibility to determine the suitability of any products to their specific application. Any product disassembly voids all warranty. Warranty can be processed nationwide by any OTR distributor, regardless of where the product was initially purchased. Only OTR products can be processed for warranty. If a product is warrantable, the product only will be replaced. This warranty is restricted to the original purchases. There are no warranties or conditions beyond this document and no person is granted authorization to express or imply additional warranty liability. The buyer's sole remedy for a warranted product is replacement of product per conditions above. In no event shall OTR, its agents or employees be responsible for incidental or consequential damages nor negligence in any respect.

9/1/19